

The Weiss Series G, inert gas actuated thermometers combine the most advanced mechanical instrument technology with the unique Weiss gas thermometer patented coil. The coil is produced by edge welding two strips of iso-elastic material and forming it into an extremely low volume, high strength, wall-to-wall C tube. The result is a system with low ambient error and extreme over-temperature capability and can provide narrow and wide ranges with the same small bulb.

## SPECIFICATIONS

ACCURACY  $\pm 1\%$  of range span.

AMBIENT ERROR 1/4% of span per 25°F change in ambient temperature at mid-scale.

OVERRANGE - minimum 50% of span above top of range or 1300°F whichever is lower. Specific over-temperature capability is range dependant, so consult the factory for application beyond the above conditions.

DIAL - white coated aluminum with black markings.

POINTER - slotted adjustable type permits "zero set" calibration.

THERMAL SYSTEMS - standard with stainless steel spring armor, (stainless steel spiral interlock is optional) spiral interlock must be furnished on systems above 40ft.

CODE	CATALOG NO.	DESCRIPTION																				
<b>I</b>	G45 G60	CASE SIZE 4 1/2" Case 6" Case																				
<b>II</b>	B E F S U V K	CASE TYPE & MATERIAL Back Flange, Aluminum Turret, Phenolic* (4 1/2" only) Front Flange, Aluminum Front Flange, Bayonet Ring, Stainless Steel U-Clamp, Bayonet Ring, Stainless Steel Vari-angle, Stainless Steel Back Flange, Bayonet Ring, Stainless Steel <small>*Flush Mounting Ring available as Accessory</small>																				
<b>III</b>	B L A	CASE CONNECTION Back Connection Lower Connection Adjustable																				
<b>IV</b>	3 4 5	CASE WINDOW Acrylic Glass Shatterproof Glass																				
<b>V</b>	0 1 8	THERMAL SYSTEM <table border="1"> <thead> <tr> <th>Bulb Type</th> <th>Bulb Material</th> <th>Capillary Material</th> <th>Capillary Protection</th> </tr> </thead> <tbody> <tr> <td>Vari-angle</td> <td>316 S.S.</td> <td>---</td> <td>---</td> </tr> <tr> <td colspan="4">(Furnished with split 1/2" NPT S.S. Swivel)</td> </tr> <tr> <td>Plain</td> <td>316 S.S.</td> <td>316 S.S.</td> <td>S.S. Spring Armor</td> </tr> <tr> <td>Sliding Union</td> <td>316 S.S.</td> <td>316 S.S.</td> <td>S.S. Spring Armor</td> </tr> </tbody> </table>	Bulb Type	Bulb Material	Capillary Material	Capillary Protection	Vari-angle	316 S.S.	---	---	(Furnished with split 1/2" NPT S.S. Swivel)				Plain	316 S.S.	316 S.S.	S.S. Spring Armor	Sliding Union	316 S.S.	316 S.S.	S.S. Spring Armor
Bulb Type	Bulb Material	Capillary Material	Capillary Protection																			
Vari-angle	316 S.S.	---	---																			
(Furnished with split 1/2" NPT S.S. Swivel)																						
Plain	316 S.S.	316 S.S.	S.S. Spring Armor																			
Sliding Union	316 S.S.	316 S.S.	S.S. Spring Armor																			
<b>VI</b>	1 4 6 9 X 7 8	BULB SELECTION Plain Bulb - Remote Dia. Length 3/8 3" (Active) + 12" Rigid Ext. Vari-angle bulb To fit Thermowell with: Dia. Length OA Len. U Insertion 3/8 4" 4.25" 2.5" 3/8 6" 6.25" 4.5 or 2.5" 3/8 9" 9.25" 7.5 or 4.5" 3/8 12" 12.25" 10.5 or 7.5" Sliding union connection bulb with bendable extension Dia. Length Extension Insertion Len. Union Thermowell - U 7 3/8 3"(Active) 12" 3 to 12" 2.5 to 10.5" 8 3/8 3"(Active) 18" 3 to 18" 2.5 to 16.5"																				
<b>VII</b>	See Example Below	SYSTEM LENGTH SPECIFYING Use 2 digits: EX. 05, 10, 80 for length required. Use FT for feet, use IN for inches																				

EXAMPLE FOR OBTAINING COMPLETE CATALOG NUMBER FROM CODES - SERIES G

CODE I-IV (HEAD ASSY)      CODE V-VI (THERMAL SYSTEM)      CODE VII (CAPILLARY LENGTH)

G45E1L4      —      87      —      05FT

ACCESSORIES - IF REQ'D

— — —

RANGE

20-240 F

B - Back Flange

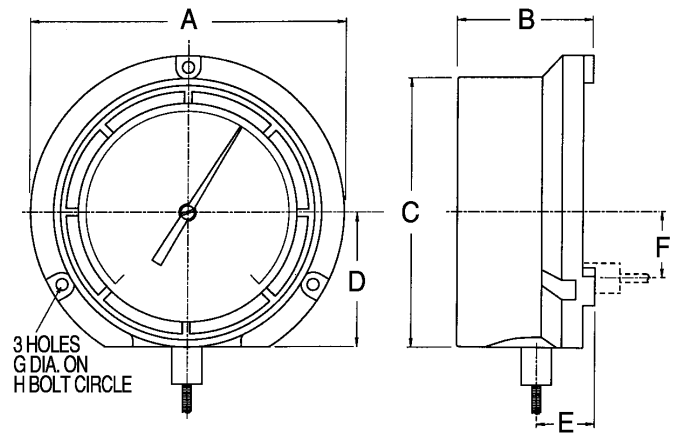

E - Turret, Phenolic

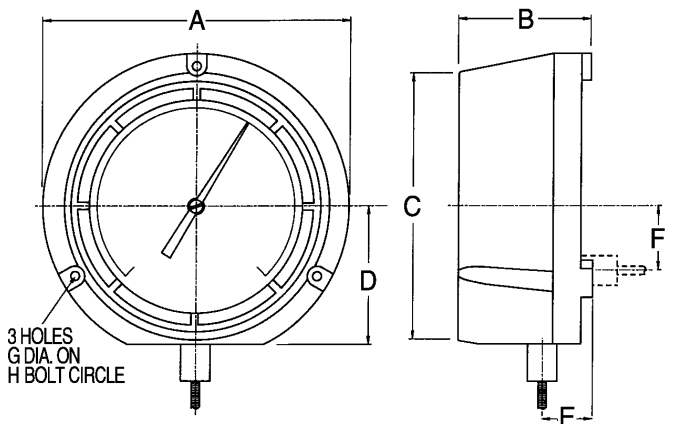

F - Front Flange

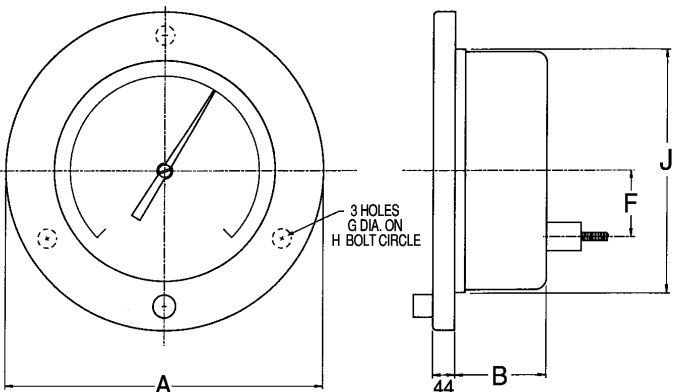

V - Vari-angle

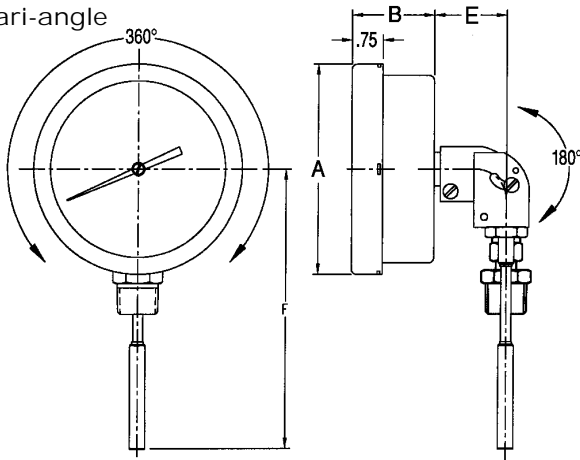

K - Back Flange

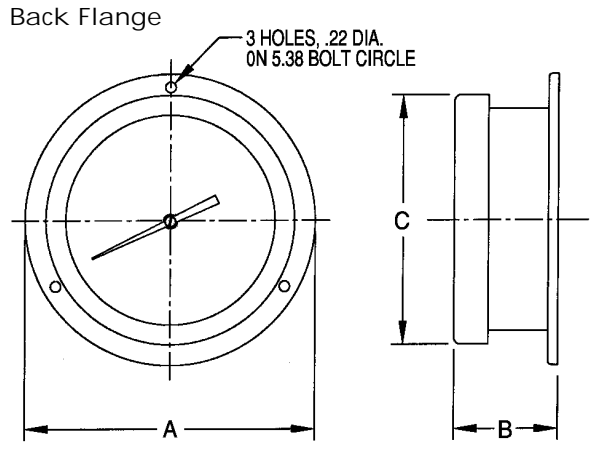

S - Front Flange

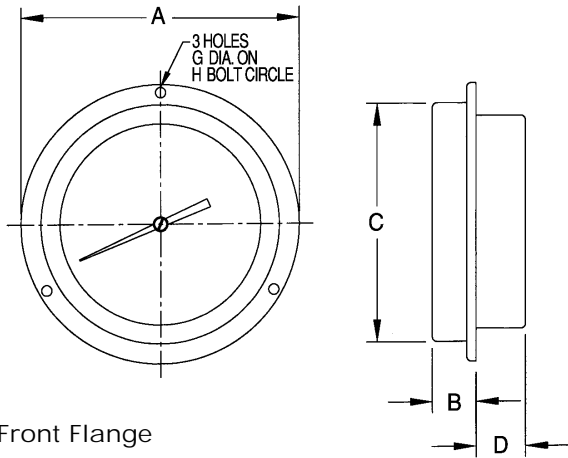

U - U-Clamp

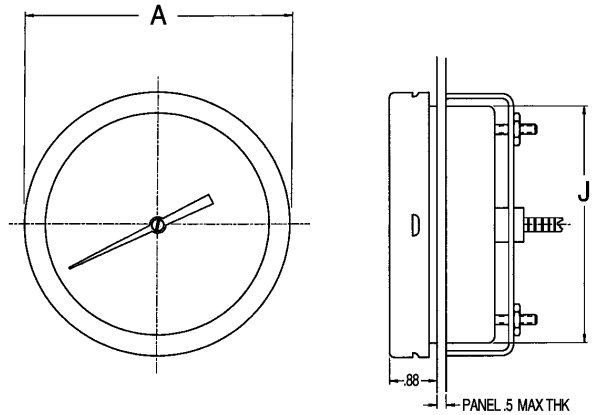

CASE DIMENSIONS

CASE SIZE	CASE TYPE	CODE I & II	FLGE DIA. A	B	RING O.D. C	D	E	F	G	H	J
4 1/2"	Back Flange	G45B	5.81	2.69	5.0	2.5	1.12	.20	.22	5.38	—
4 1/2"	Turret Phenolic	G45E	5.83	2.56	5.08	2.62	1.0	.20	.24	5.39	—
4 1/2"	Front Flange	G45F	6.31	1.63	—	—	—	1.35	.19	5.38	4.88
4 1/2"	Vari-angle	G45V	5.04	2.00	—	—	1.75	6.81	—	—	—
4 1/2"	Front Flange	G45S	5.89	.94	5.05	1.04	—	—	.22	5.55	—
4 1/2"	U-Clamp	G45U	5.04	—	—	—	—	—	—	—	4.51
4 1/2"	Back Flange	G45K	5.90	2.10	5.05	—	—	—	.22	5.38	—
6"	Back Flange	G60B	7.65	2.26	6.25	3.31	1.0	1.75	.28	7.00	—
6"	Front Flange	G60F	7.87	1.59	—	—	—	1.75	—	—	6.34
6"	Vari-angle	G60V	6.38	2.15	—	—	1.75	6.81	—	—	—
6"	Front Flange	G60S	7.51	.94	6.35	—	—	—	.25	6.89	—
6"	U-Clamp	G60U	6.38	—	—	—	—	—	—	—	5.88
6"	Back Flange	G60K	7.50	2.10	6.33	—	—	—	—	—	—

THERMAL SYSTEM & BULB SELECTION - CODE V-VI

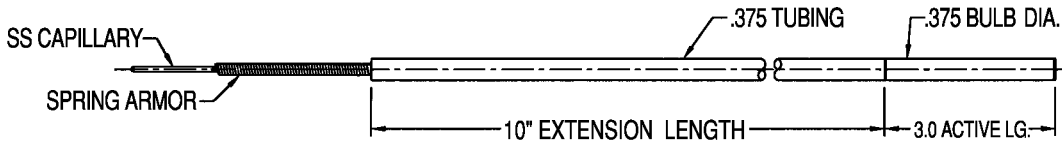

PLAIN BULB

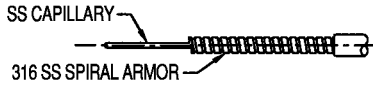

SYSTEM CODE	BULB TYPE	BULB MAT'IAL	CAPILLARY MATERIAL	CAPILLARY PROTECTION
1	1	Plain	316 S.S.	316 S.S.
				SS Spring Armor

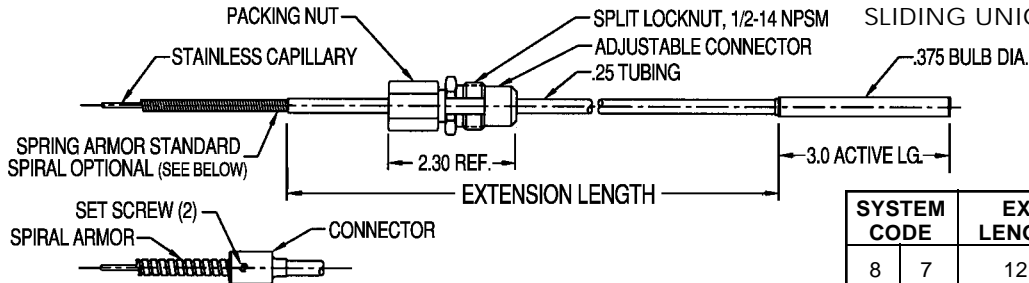

SLIDING UNION - BENDABLE EXTENSION

SYSTEM CODE	EXT. LENGTH	INSERTION U		
		UNION	T-WELL	
8	7	12"	3 to 12"	2.5 to 10.5"
8	8	18"	3 to 18"	2.5 to 16.5"

Thermowell is required for this Bulb Assy.

VARI-ANGLE

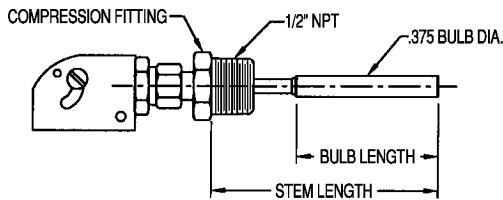

SYSTEM CODE	STEM LENGTH	INSERTION U		
		UNION	T-WELL	
0	4	4"	3.4"	2.5"
0	6	6"	5.6"	4.5"
0	9	9"	8.4"	7.5"
0	X*	12"	11.4"	10.5"

Thermowell is recommended for this Bulb Assy.

\*X designation used for bulb lengths of 12" or longer.

PROCESS CONNECTION FITTINGS

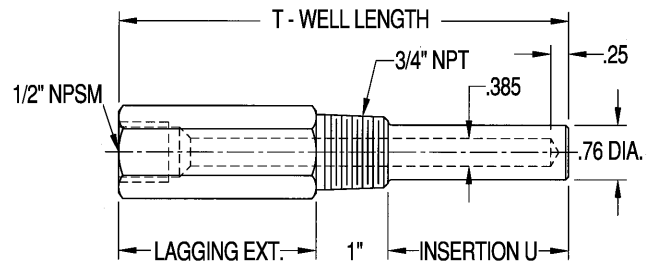
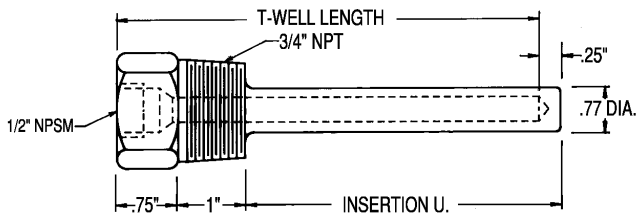

THERMOWELLS WITHOUT LAGGING EXTENSION				THERMOWELLS WITH LAGGING EXTENSION				
CATALOG NO.*	T-WELL LENGTH	STEM LGTH.	INSERTION U	CATALOG NO.*	T-WELL LENGTH	STEM LGTH.	LAG. EXT.	INSERTION U
GT004-75	4.25"	4"	2.5"	GT206-75	6.25"	6"	2.75"	2.5"
GT006-75	6.25"	6"	4.5"	GT309-75	9.25"	9"	3.75"	4.5"
GT009-75	9.25"	9"	7.5"	GT312-75	12.25"	12"	3.75"	7.5"
GT012-75	12.25"	12"	10.5"					

\*Complete Catalog No. is obtained by adding 5 character designation for Thermowell Material. Ex: GT004-75-BRASS  
 GT006-75-304SS  
 GT009-75-316SS

## STANDARD RANGES

-320/100F	-120/120F	-40/180F	0/120F	60/120F	20/240F	0/300F	50/550F	50/750F	400/1200F
-----------	-----------	----------	--------	---------	---------	--------	---------	---------	-----------

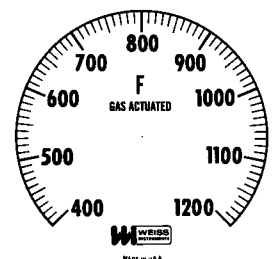
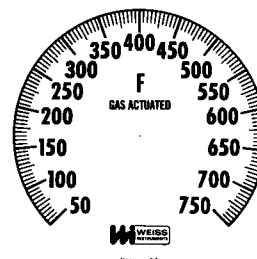
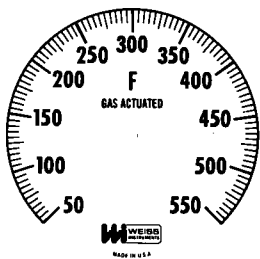
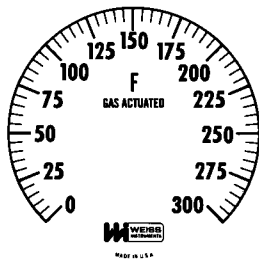
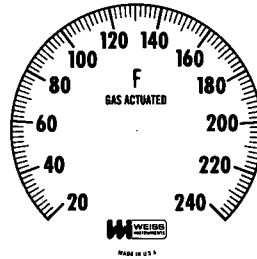
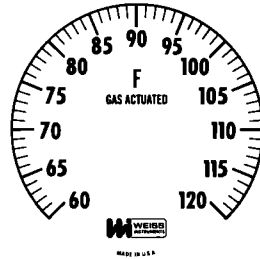
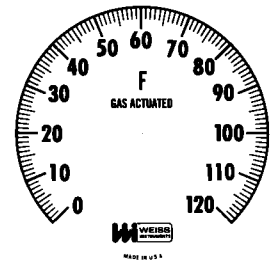
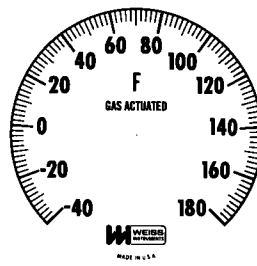
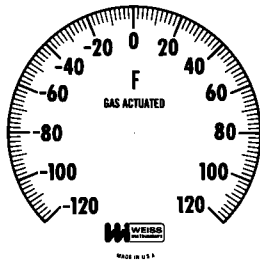
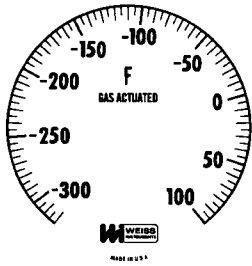

NOTE: Centigrade and Dual Scales are available upon request.

## ACCESSORIES

### SPIRAL INTERLOCKING ARMOR



Available for all Remote Systems.  
Required on Line Lengths above 40Ft.  
Specify: SIA

### FLUSH MOUNTING RING

For 4 1/2" E Case Only  
Specify: FMR

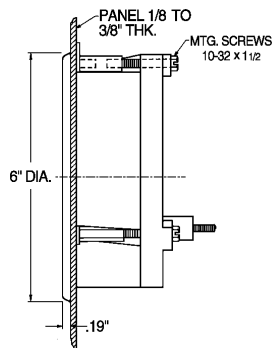

For mounting 4 1/2" Phenolic Case to panel.

### LAZY HAND ASSEMBLY

For 4 1/2" E & B Case Only  
Specify: LHA



For Indicating Highest or Lowest Temperatures Achived.  
Re-setable by Front Knob.