

REV	ECN No.	DESCRIPTION	BY	DATE
A	N/A	RELEASED	MC	2009 09 10

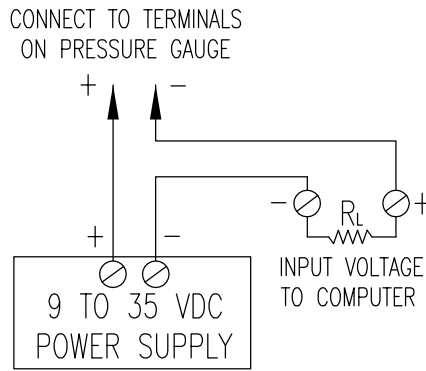
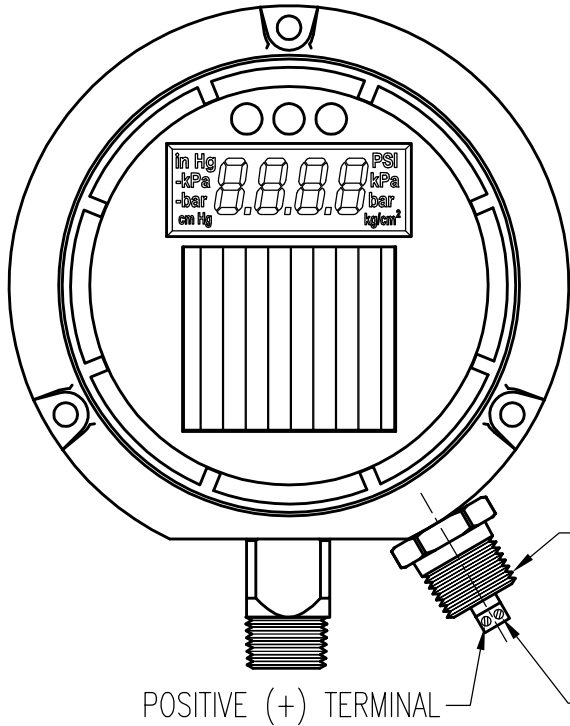

VOLTAGE/PRESSURE EXAMPLE FOR 200PSI  $R_L=250\Omega$

V (250 $\Omega$ )	mA	PSI
1.0	4.0	0
1.2	4.8	10
1.4	5.6	20
1.6	6.4	30
1.8	7.2	40
2.0	8.0	50
2.2	8.8	60
2.4	9.6	70
2.6	10.4	80
2.8	11.2	90
3.0	12.0	100
3.2	12.8	110
3.4	13.6	120
3.6	14.4	130
3.8	15.2	140
4.0	16.0	150
4.2	16.8	160
4.4	17.6	170
4.6	18.4	180
4.8	19.2	190
5.0	20.0	200

INSTALLATION INSTRUCTIONS FOR 4 TO 20 mA TRANSMITTER:

THE WEISS DUGY-T DIGITAL PRESSURE GAUGE INCLUDES A 4 TO 20mA TRANSMITTER OPTION AND IS DUAL POWERED BY BOTH THE SOLAR CELL AND THE CURRENT LOOP, NO BATTERIES ARE NEEDED. IF THE POWER LOOP IS OFF, THE GAUGE AUTOMATICALLY SWITCHES TO LIGHT POWER.

BOTH THE DISPLAY AND 4 TO 20mA CURRENT ARE FACTORY CALIBRATED AND SYNCHRONIZED FOR THE HIGHEST ACCURACY. THE ZERO ADJUST FEATURE (SEE DUGY INSTRUCTIONS) WILL ADJUST BOTH THE DISPLAY AND THE CURRENT. THE DEFAULT CURRENT IS SET FOR 4mA AT 0 PSI AND 20mA AT THE TOP OF THE RANGE. THE CURRENT CHANGE IS LINEAR WITHIN THE RANGE. FOR EXAMPLE A 0-200 PSI GAUGE WILL HAVE 4mA AT 0 PSI, 12 mA AT 100 PSI AND 20mA AT 200 PSI. DIFFERENT TRANSMITTER SETTINGS ARE AVAILABLE\*.

A BASIC WIRING DIAGRAM IS SHOWN ABOVE. IF CONVERSION TO VOLTAGE IS DESIRED, A PRECISION 0.5 TO 1 WATT RESISTOR SHOULD BE USED. WEISS RECOMMENDS USING A 250 OHM, 0.1% 1 WATT RESISTOR. REFER TO THE SAMPLE CHART ABOVE: 4mA EQUALS 1 VOLT, 20mA EQUALS 5 VOLTS.

THE WIRE CONNECTOR IS SEALED IN A 1/2 NPT FITTING AS SHOWN ON THIS DRAWING. CARE SHOULD BE TAKEN WHEN CONNECTING THE TERMINALS TO MAINTAIN THE RIGHT POLARITY. THE POSITIVE TERMINAL IS MARKED WITH A "+".

\* IF OTHER CURRENT SETTINGS ARE REQUIRED, PLEASE SPECIFY WHEN ORDERING. THE 4mA AND 20mA POINTS CAN BE ASSIGNED TO ANY PRESSURE VALUES WITHIN THE RANGE OF THE GAUGE. COMPOUND VACUUM/PRESSURE GAUGES DEFAULT SETTING IS 4mA AT 0 PSI.

DRAWING PER ANSI Y14.5M-1994		TITLE:		<b>WEISS INSTRUMENTS, INC.</b> A Quality Commitment - Since 1882 905 WAVERLY AVE., HOLTSVILLE, NEW YORK 11742 PHONE: 631 207 1200 - FAX: 631 207 0900 <a href="http://www.weissinstruments.com">www.weissinstruments.com</a>	
ALL DIMENSIONS ARE IN INCHES. TOLERANCES UNLESS SPECIFIED:		<b>DUGY-T 4 TO 20 mA TRANSMITTER INSTRUCTIONS</b>			
DECIMAL .XX ±.010 DECIMAL .XXX ±.005 ANGLES ±1°		DRAWN: M CUBILLO		DATE: 2009 09 10	
THIRD ANGLE PROJECTION		APPVD: JOHN WEISS		SCALE: 1:2	
				DRAWING NO: 515-0034	
				REV A	