

SPECIFICATIONS

DIAL SIZE - 3 1/2 and 4 1/2 inch.
CASE & RING - drawn stainless steel case with snap-in "O" ring gasketed clear lexan.
CASE STYLES - to accommodate wall or panel mounting (as shown).
DIAL - white coated aluminum with black markings.
POINTER - slotted adjustable type.
BOURDON TUBE - phosphor bronze.
THERMAL BULB & LINE ASSEMBLY - copper.
PROCESS CONN. FITTING - air duct flange.
ACCURACY - one scale division throughout range.

BL Case - Wall Mount Bottom Connected

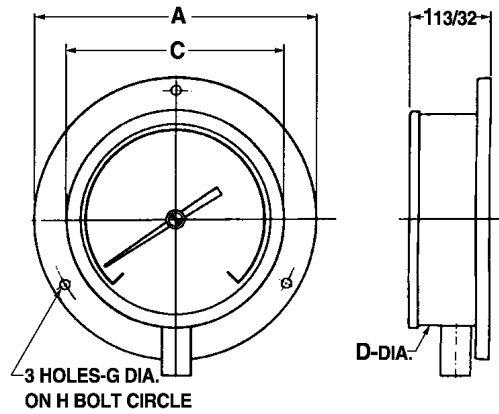

ZL Case - Adjustable Bracket Mount

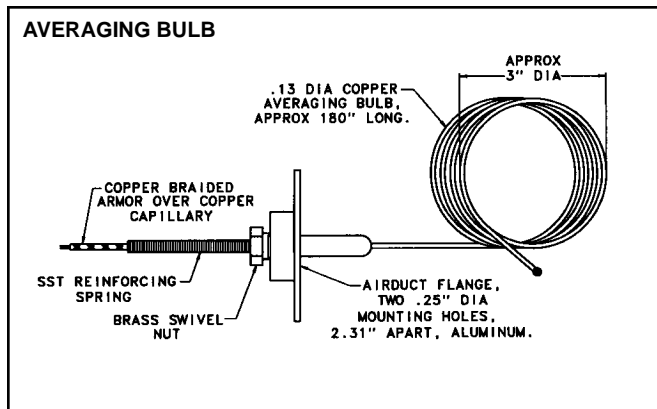
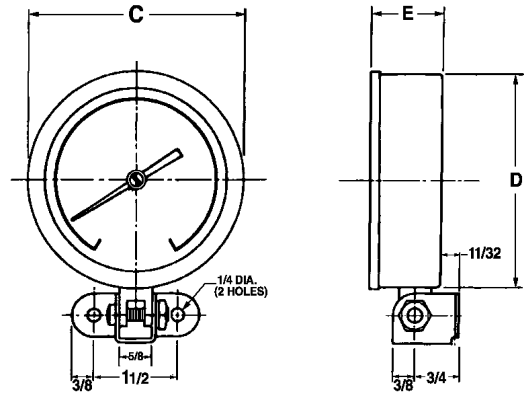

DIAL SIZE	A	C	D	E	G	H
3 1/2"	4 3/4	3 11/16	3 19/32	1 1/4	5/32	4 5/16
4 1/2"	5 7/8	4 11/16	4 19/32	1 1/4	7/32	5 3/8

°F RANGES
40-0-110°F
20-0-100°F
0-150°F
0-180°F
40-240°F
30-300°F
100-350°F

QTY.	DIAL SIZE	CASE STYLE	RANGE	CAPILLARY LENGTH*	TAG

NOTE: Dual Scales available.

*Distance between Indicating Head and Mounting Flange.

CUSTOMER _____
PROJECT _____
ENGINEER _____
PRO or P.O. NO. _____



WEISS INSTRUMENTS, INC.
HOLTSVILLE, NEW YORK 11742

DESCRIPTION:
Remote Reading Vapor Actuated Dial Thermometer
Averaging Bulb Construction

DRAWN BY: _____ DATE: _____ DRAWING: _____